

Scheme I

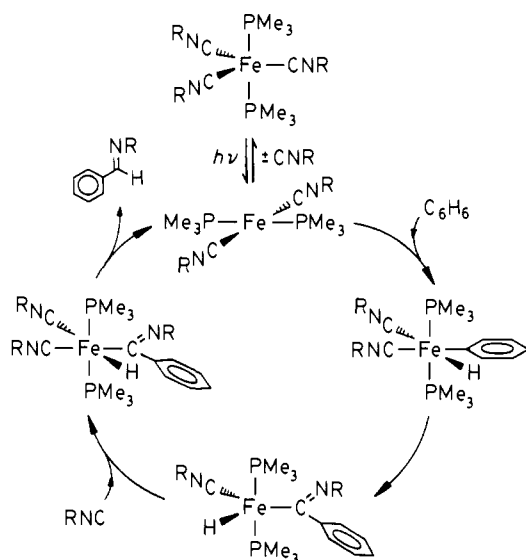

$(\text{PMe}_3)_2(\text{CNR})_3$ for a variety of R groups (R = Me, *t*-Bu, CH_2CMe_3 , Ph, 2,6-xylyl; eq 2).¹⁴ Most of these complexes are thermally stable below 60 °C, at which temperature phosphine is readily and reversibly lost as evidenced by exchange with $\text{P}(\text{CD}_3)_3$.

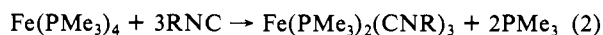

Pyrex-filtered irradiation (Hg or W) of a ~0.023 M benzene solution of the complex $\text{Fe}(\text{PMe}_3)_2(\text{CNCH}_2\text{CMe}_3)_3$, **1**, ($\lambda_{\text{max}} = 327 \text{ nm}$) results in the formation of aldimine $\text{PhCH}=\text{NCH}_2\text{CMe}_3$ in 88% yield (based on iron). A new organometallic product is also formed in 35% yield and is identified as $\text{Fe}(\text{PMe}_3)_3(\text{CNCH}_2\text{CMe}_3)_2$, **2**, on the basis of its ^1H and ^{31}P NMR spectrum (eq 3). A similar experiment in toluene solution gives a 2.8:1

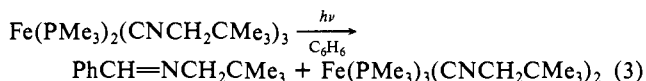

mixture of the analogous *m*- and *p*-tolylaldimines in 55% combined yield. Irradiation of the xylyl isocyanide complex $\text{Fe}(\text{PMe}_3)_2(\text{CN-2,6-C}_6\text{H}_3\text{Me}_2)_3$ in benzene (~0.008 M) also gives the corresponding aldimine in 89% yield (based on iron) after 40 min of irradiation.¹⁵

Preliminary mechanistic studies have allowed the formulation of a probable sequence of events. Irradiation of a benzene solution of $\text{Fe}(\text{PMe}_3)_2(\text{CN-2,6-C}_6\text{H}_3\text{Me}_2)_3$ and $\text{Me}_3\text{CCH}_2\text{NC}$ at -55 °C shows in the formation of free CN-2,6-xylyl and PMe_3 in a 1:2 ratio.¹⁶ Irradiation of **1** in the presence of PMe_3 produces **2**, as indicated by changes in the ^1H NMR spectrum of the sample. These observations are consistent with the photochemical labilization of the π -acceptor isocyanide ligand in addition to the σ -donor PMe_3 group. Irradiation of **1** in C_6D_6 solvent gives $\text{C}_6\text{D}_5\text{CD}=\text{NCH}_2\text{CMe}_3$ as determined by ^1H NMR spectroscopy and mass spectral data, indicating that the solvent (and not the PMe_3 ligand) is the source of the aldimine hydrogen.

The mechanism proposed in Scheme I indicates the sequence of events anticipated upon production of the low valent electron rich intermediate $[\text{Fe}(\text{PMe}_3)_2(\text{CNR})_2]$. It is interesting to note that the thermally accessible intermediate $[\text{Fe}(\text{PMe}_3)(\text{CNR})_3]$ does not produce aldimine; apparently the species with three

(14) Details of the preparation, ^1H and ^{31}P NMR data, IR, mass spectra, analyses, and X-ray structures of these complexes are reported elsewhere: Jones, W. D.; Foster, G. P.; Putinas, J. M. *Inorg. Chem.* **1987**, *26*, 2120-2127.

(15) The aldimine products were identified by comparison of their ^1H NMR spectra and GC retention times with those of authentic samples. The organometallic products were identified by their characteristic ^1H NMR resonances and coupling patterns.

(16) The low temperature was used in order to ensure the absence of thermal scrambling of the isocyanide ligands prior to photolysis.

Table I. Yield of $\text{PhCH}=\text{NCH}_2\text{CMe}_3$ upon Irradiation of **1** and $\text{CNCH}_2\text{CMe}_3$ in Benzene Solution

[1]	$[\text{CNCH}_2\text{CMe}_3]$	no. of turnovers ^a	% conversn ^b
0.004	0.004	2.1	53
0.002	0.004	3.5	69
0.001	0.004	5.1	72
0.0005	0.004	6.6	60
0.00025	0.004	8.4	44
0.0005	0.0005	2.7	67
0.0005	0.001	4.9	97
0.0005	0.002	5.7	82
0.0005	0.004	7.5	68
0.0005	0.008	7.1	37
0.0005	0.016	0.6	2

^aBased on iron. ^bBased on total isocyanide, both in **1** and free in solution.

π -acceptor ligands is not sufficiently "electron rich" to induce benzene oxidative addition.

The proposed mechanism indicates that in the presence of added RNC, the aldimine-producing reaction should be catalytic with respect to iron. However, since the role of light is to induce isocyanide dissociation, the back-reaction of RNC with $[\text{Fe}(\text{PMe}_3)_2(\text{CNR})_2]$ to give **1** must be suppressed by keeping the absolute concentration of isocyanide very low. As shown in Table I, catalytic behavior with respect to iron and efficient conversion of both the free and coordinated isocyanide can be obtained by working in the mM concentration range. The catalysis stops if irradiation is discontinued.

Irradiation of **1** in cyclohexane or pentane solution at 25 °C or at -55 °C does not lead to alkane functionalization. Apparently, $[\text{Fe}(\text{PMe}_3)_2(\text{CNCH}_2\text{CMe}_3)_2]$ does not oxidatively add to alkanes.¹⁷

Acknowledgment is made to the U. S. Department of Energy (DE-FG02-86ER13569) for their partial support of this work. W.D.J. also thanks the Alfred P. Sloan and Camille and Henry Dreyfus Foundations for awards.

(17) A recent example of alkane oxidative addition to $[\text{Fe}(\text{dmpe})_2]$ has been observed: Baker, M. V.; Field, L. D. *J. Am. Chem. Soc.* **1987**, *109*, 2825-2826.

Direct Observation of a Dienolate Intermediate in the Base-Catalyzed Isomerization of 5-Androstene-3,17-dione to 4-Androstene-3,17-dione

Ralph M. Pollack,* Joseph P. G. Mack, and Sherif Eldin

Laboratory for Chemical Dynamics
Department of Chemistry
University of Maryland Baltimore County
Baltimore, Maryland 21228

Received April 9, 1987

We describe here the first direct observation of an intermediate dienolate ion during the base-catalyzed isomerization of a β,γ -unsaturated ketone to its conjugated isomer. In addition, we report the ionization constant for this β,γ -unsaturated ketone (5-androstene-3,17-dione) in aqueous solution as well as the rate constants for the formation of the dienolate ion intermediate and its protonation at both β - and γ -carbon atoms.

The conversion of β,γ -unsaturated carbonyl compounds to their α,β -unsaturated isomers is a simple example of a larger class of prototropic rearrangements.¹ This reaction has been examined by several groups for both acidic² and basic^{2d,e,g,3} solutions. In

(1) March, J. *Advanced Organic Chemistry*, 3rd ed.; Wiley, New York, 1985; p 524.

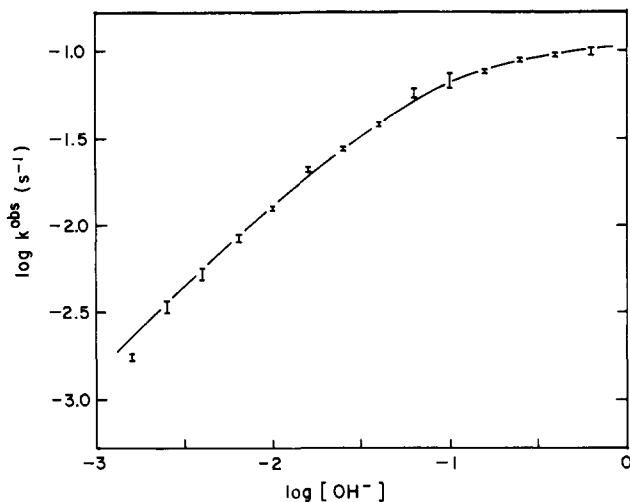

Figure 1. Plot of $\log k^{\text{obsd}}$ vs. hydroxide ion concentration for the isomerization of 5-androstene-3,17-dione to 4-androstene-3,17-dione at 25.0 °C, 5% methanol, $\mu = 1.0$. The curve is theoretical based on eq 2 with $K = 12 \text{ M}^{-2}$ and $k_2 = 0.122 \text{ s}^{-1}$.

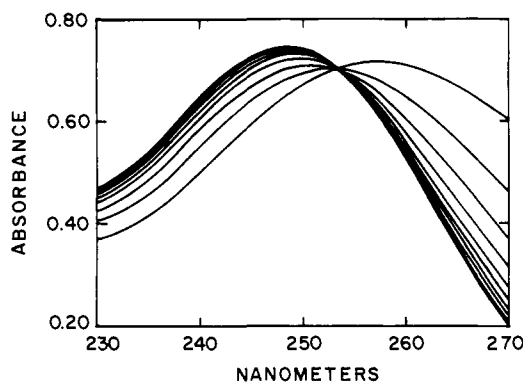

Figure 2. Repetitive scans of a solution of 10^{-4} M 5-androstene-3,17-dione in 1.0 M sodium hydroxide. Each scan was taken about 2–3 s apart.

addition, the conjugation of Δ^5 -3-ketosteroids by the enzyme steroid isomerase has been investigated in some detail.⁴ The accepted mechanism for these reactions involves the formation of a dienol intermediate in either its neutral or anionic form. Although conjugated enols have been shown to react under appropriate conditions, both enzymatically⁵ and nonenzymatically,⁶ to generate either the corresponding α,β - or β,γ -unsaturated carbonyl compounds, there have been no previous reports of the direct observation of a dienol or dienolate ion during the isomerization reaction itself.

(2) (a) Kawahara, F. S.; Wang, S. F.; Talalay, P. *J. Biol. Chem.* **1962**, *237*, 1500. (b) Nes, W. R.; Loeser, E.; Kirdani, R.; Marsh, J. *Tetrahedron* **1963**, *19*, 299. (c) Malhotra, S. K.; Ringold, H. J. *J. Am. Chem. Soc.* **1965**, *87*, 3228. (d) Jones, J. B.; Wigfield, D. C. *J. Am. Chem. Soc.* **1967**, *89*, 5294. (e) Jones, J. B.; Wigfield, D. C. *Can. J. Chem.* **1968**, *46*, 1459. (f) Jones, J. B.; Wigfield, D. C. *Can. J. Chem.* **1969**, *47*, 4459. (g) Noyce, D. S.; Evett, M. *J. Org. Chem.* **1972**, *37*, 394, 397.

(3) (a) Subrahmanyam, G.; Malhotra, S. K.; Ringold, H. J. *J. Am. Chem. Soc.* **1966**, *88*, 1332. (b) Whalen, D. L.; Weimaster, J. F.; Ross, A. M.; Radhe, R. *J. Am. Chem. Soc.* **1976**, *98*, 7319.

(4) For review, see: (a) Batzold, F. H.; Benson, A. M.; Covey, D. F.; Robinson, C. H.; Talalay, P. *Adv. Enzyme Regul.* **1976**, *14*, 243–267. For more recent references, see: (b) Pollack, R. M.; Bantia, S.; Bounds, P. L.; Koffman, B. M. *Biochemistry* **1986**, *25*, 1905. (c) Bevins, C. L.; Pollack, R. M.; Kayser, R. H.; Bounds, P. L. *Biochemistry* **1986**, *25*, 5159. (d) Westbrook, E. M.; Sigler, P. B. *J. Biol. Chem.* **1984**, *259*, 9090. (e) Westbrook, E. M.; Sigler, P. B. *J. Biol. Chem.* **1984**, *259*, 9096. (f) Hearne, M.; Benisek, W. F. *Biochemistry* **1985**, *24*, 7511. (g) Hearne, M.; Benisek, W. F. *J. Protein. Chem.* **1984**, *3*, 87.

(5) Bantia, S.; Pollack, R. M. *J. Am. Chem. Soc.* **1986**, *108*, 3145.

(6) (a) Duhaime, R. M.; Weedon, A. C. *J. Am. Chem. Soc.* **1985**, *107*, 6723. (b) Duhaime, R. M.; Weedon, A. C. *J. Am. Chem. Soc.* **1987**, *109*, 2479. (c) Pollack, R. M.; Mack, J. P. G.; Blotny, G. *J. Am. Chem. Soc.* **1987**, *109*, 3138.

When 5-androstene-3,17-dione (**1**) is added to aqueous solutions of sodium hydroxide (0.001–0.8 M) and the reaction is monitored by ultraviolet spectroscopy, an increase in absorbance at 248 nm, due to the formation of 4-androstene-3,17-dione (**2**), may be observed. The reaction accurately follows pseudo-first-order kinetics, giving rate constants that show saturation with increasing hydroxide ion concentration (Figure 1), consistent with the formation of an intermediate dienolate ion in significant amounts (eq 1). Analysis of the variation of the observed rate constant

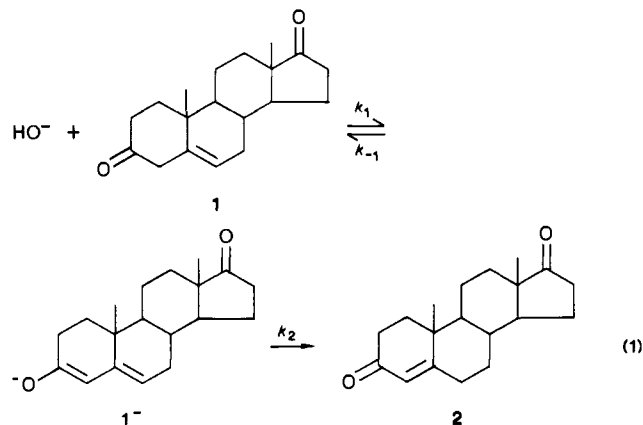

with hydroxide ion shows that the data fit the corresponding rate expression (eq 2) with values of $12 \pm 2 \text{ M}^{-1}$ for $K (= k_1/k_{-1})$ and

$$k^{\text{obsd}} = k_2 K [\text{OH}^-] / (1 + K [\text{OH}^-]) \quad K = k_1/k_{-1} \quad (2)$$

$0.122 \pm 0.007 \text{ s}^{-1}$ for k_2 at 25.0 °C and $\mu = 1.0$ (KCl, 5% methanol).⁷ This value for K may be converted to a $\text{p}K_a$ of 12.72 ± 0.08 for 5-androstene-3,17-dione.⁸

In order to verify that the observed rate law is due to the formation of significant quantities of the dienolate, a rapid spectral scan over the range 280–220 nm was taken about 2–3 s after the addition of the substrate to 1.0 M hydroxide ion solution. An intense peak at 256 nm (ϵ about 15 000) was immediately apparent. The absorbance at this wavelength decreases as the reaction proceeds with a concomitant increase in absorbance at 248 nm (Figure 2). An excellent isosbestic point for the conversion of this species to product is consistent with the involvement of the dienolate in the isomerization.

The rate of formation of this intermediate was monitored by stopped-flow spectrophotometry at the isosbestic point for several concentrations of hydroxide ion. A linear relationship between the observed rate constant and the hydroxide ion concentration was observed (eq 3), giving values for $k_1 = 41.1 \pm 0.6 \text{ M}^{-1} \text{ s}^{-1}$

$$k^{\text{obsd}} = k_1 [\text{OH}^-] + k_{-1} \quad (3)$$

and $k_{-1} = 3.03 \pm 0.05 \text{ s}^{-1}$. combined with the value of k_2 , this result gives a partitioning ratio for the intermediate of $k_{-1}/k_2 = 25$. Division of k_1 by k_{-1} yields a value of $K = 13.6 \pm 0.4$, corresponding to a $\text{p}K_a$ of 12.67 ± 0.02 , in excellent agreement with the $\text{p}K_a$ obtained from the kinetics of the isomerization reaction.

The acidity of 5-androstene-3,17-dione ($\text{p}K_a = 12.7$) may be compared to the acidity of saturated ketones that have been examined in aqueous solution. Kresge, Wirz, and co-workers have determined the $\text{p}K_a$'s of acetone (19.16),¹⁰ acetophenone (18.31),⁹ and isobutyrophenone (18.26)¹¹ by measurement of the keto–enol

(7) The rate of hydroxide ion catalyzed isomerization of 5-androstene-3,17-dione in aqueous solutions has been measured previously at pH values of 10.6 to 11.7.^{2f} Our rate constants are about sevenfold smaller in that pH range than the literature values.

(8) This $\text{p}K_a$ is a concentration equilibrium constant, based upon a value of $1.59 \times 10^{-14} \text{ M}^2$ for the ion product of water in solutions of ionic strength = 0.1.⁹ Additional studies in solutions of ionic strength = 0.1 show that the same value of K is obtained as in solutions of ionic strength = 1.0.

(9) Chiang, Y.; Kresge, A. J.; Wirz, J. *J. Am. Chem. Soc.* **1984**, *106*, 6392.

(10) Chiang, Y.; Kresge, A. J.; Tang, Y. S.; Wirz, J. *J. Am. Chem. Soc.* **1984**, *106*, 460.

(11) Pruszyński, P.; Chiang, Y.; Kresge, A. J.; Schepp, N. P.; Walsh, P. A. *J. Phys. Chem.* **1986**, *90*, 3760.

equilibrium constants and the ketonization rates of the corresponding enols as a function of pH. Although these ketones are not directly comparable to **1**, it is apparent that the introduction of a double bond β,γ to the carbonyl group has a large ($>10^5$ -fold) effect on the ionization of the α -hydrogen. The relatively acidic nature of this hydrogen may prove to be important in the elucidation of the mechanism of steroid isomerase.

Acknowledgment. This work was supported by Grant No. GM-33059 from the National Institutes of Health. We thank Dr. Dale L. Whalen for helpful discussions.

Generation of Mono- and Dianions of 1,4-Diphenyl-2-tetrazene by Nonoxidative N-N Bond Formation. A Novel Route to a 2-Tetrazene, a Silacyclotetrazene, and the Tetrazenide Complex (1,4-Diphenyltetrazenido)bis(triethylphosphine)-palladium

Soon W. Lee,^{1a} Glenn A. Miller,^{1a} Charles F. Campana,^{1b} Mary L. Maciejewski,^{1a} and William C. Troglor*^{1a}

Department of Chemistry, D-006
The University of California at San Diego
La Jolla, California 92093
Nicolet Instrument Corporation
Madison, Wisconsin 53711-0370

Received May 4, 1987

Most methods for making N-N bonds use oxidizing conditions.² For example, 2-tetrazenes are synthesized by oxidation of unsymmetrically disubstituted hydrazines.² Carbanion reagents have proved useful for forming bonds between carbon and many elements. For example, Trost and Pearson³ prepared triazenes from the reaction between phenylthiomethylazides and aryl Grignard reagents. Analogous reactions between alkyl amide anions and toluenesulfonyl azide were earlier used⁴ to transfer the alkyl group of an amide to the azide. The intermediate in this reaction was postulated to be a tetrazenide anion. The only known tetrazenide dianion $\text{Li}_2[(\text{Me}_2\text{Si})\text{NN}=\text{NN}(\text{Me}_2\text{Si})]$ is not easily synthesized.^{5,6} In an attempt to prepare symmetrically disubstituted dianions of 2-tetrazenes by the removal of benzoyl groups from 1,4-dibenzoyl-1,4-diphenyl-2-tetrazene,⁷ $\text{Ph}(\text{PhCO})\text{NN}=\text{NN}(\text{COPh})\text{Ph}$, we observed that addition of alkyllithium or Grignard reagents caused fragmentation to phenyl azide (PhN_3) and sodium benzanilide $\text{Na}[\text{Ph}(\text{PhCO})\text{N}]$.⁷ Fragmentation of an incipient tetrazenide monoanion may occur because the oxygen of the carbonyl group better stabilizes negative charge than the π -system of the tetrazene moiety. This raised the question whether the reverse process, addition of a nonstabilized amide ion to an organic

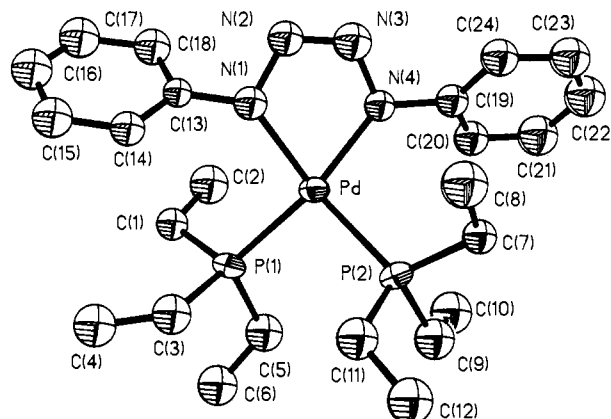
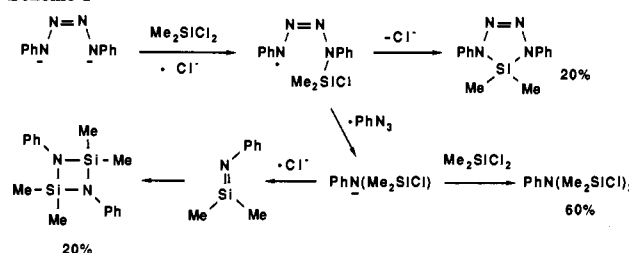
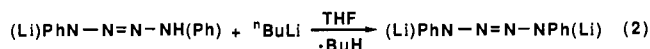

Figure 1. ORTEP drawing of compound III showing the atom labeling scheme and 50% probability thermal ellipsoids.

Scheme I



azide, eq 1, might provide a simple route to tetrazenide mono- and dianions, eq 1 and 2.



A solution of LiNHPh was prepared by adding 10.3 mL of 1.6 M *n*-BuLi (16.5 mmol) in hexane to 1.5 mL (16.5 mmol) of aniline in 25 mL of THF. To this solution was added 7.8 mL (16.5 mmol) of 2.17 M PhN_3 in toluene⁸ and an unstable yellow solid, $[\text{Li}(\text{THF})_x][\text{N}(\text{Ph})\text{NNNH}(\text{Ph})]$, formed. After 1 h 30.9 mL (49.5 mmol) more of the *n*-BuLi solution was added slowly and stirred for 1 h. The yellow slurry of $[\text{Li}(\text{THF})_x]_2[\text{PhN}_4\text{Ph}]$, **I**, was filtered, and the precipitate was washed with hexane. The resulting pyrophoric yellow solid (4.70 g) was dried under vacuum and stored under N_2 . Complex **I** exhibits a slight solubility in THF and benzene. Protic solvents cleave **I** to regenerate aniline and phenyl azide.⁹

Complex **I** serves as a convenient source of the $\text{PhN}^--\text{N}=\text{N}-\text{N}^--\text{Ph}$ dianion. Addition of 2 equiv of CH_3I to **I** produces $\text{Ph}(\text{Me})\text{NN}=\text{NN}(\text{Me})\text{Ph}$ in 60% isolated yield.¹⁰ Treatment of 1.0 g of **I** in 20 mL of THF at -80°C with 10 mL (10 mmol) of a 1.0 M solution of dichlorodimethylsilane (in pentane) gave a light yellow solution. The solution was warmed slowly to room temperature, and the volatiles were removed. Extraction of the residue with warm pentane, followed by concentration and cooling to -80°C , gave the crystalline cyclic tetrazenene derivative,

(1) (a) University of California at San Diego. (b) Nicolet Instrument Corporation.

(2) Smith, P. A. S. *Derivatives of Hydrazine and Other Hydronitrogens Having N-N Bonds*; Benjamin/Cummings: London, 1983.

(3) Trost, B. M.; Pearson, W. H. *J. Am. Chem. Soc.* **1981**, *103*, 2483.

(4) Anselme, J.-P.; Fischer, W. *Tetrahedron* **1969**, *25*, 855.

(5) Wiberg, N.; Bayer, H.; Vasisht, S. K. *Chem. Ber.* **1981**, *114*, 2658.

(6) Wiberg, N.; Vasisht, S. K.; Bayer, H.; Meyers, R. *Chem. Ber.* **1979**, *112*, 2718.

(7) The 1,4-dibenzoyl-1,4-diphenyl-2-tetrazene was prepared in 35% yield by oxidation of *N,N*-benzoylphenylhydrazide with lead tetraacetate in CH_2Cl_2 -pyridine: IR (KBr) 1645 cm^{-1} (vs); $^1\text{H NMR}$ (CDCl_3) δ 7.28 (m, Ph), 7.00 (m, Ph) 6.88 (m, Ph). Anal. Calcd for $\text{C}_{26}\text{H}_{20}\text{N}_4\text{O}_2$: C, 74.27; H, 4.76; N, 13.32. Found: C, 74.08; H, 4.94; N, 13.08. For the reaction with methyl lithium in diethyl ether (aqueous quench) the fragmentation product PhN_3 was identified by its IR spectrum (2125 cm^{-1} (s) and 2095 cm^{-1} (s)). The 2-phenyl-2-propanol was identified by comparison of its $^1\text{H NMR}$ spectrum and GLC retention time with those of an authentic sample purchased from Aldrich Chemicals.

(8) PhN_3 was prepared as in the following: Lindsay, R. O.; Allen, C. F. H. *Organic Synthesis*; Wiley: New York, 1955; Collect. Vol. III, p 710. The concentration of PhN_3 in toluene was determined by a modified iodometry procedure: Leffler, J. E.; Tsuno, Y. *J. Org. Chem.* **1963**, *28*, 190. Carpenter, W. R. *Anal. Chem.* **1964**, *36*, 2352. Caution: *Phenyl azide is explosive; however, it can be stored and used as a nonexplosive toluene solution.*

(9) Fragmentation of tetrasubstituted 2-tetrazenes has also been observed by the following: Koga, G.; Anselme, J.-P. *J. Am. Chem. Soc.* **1969**, *91*, 4323. Wadsworth, W. J. *J. Org. Chem.* **1969**, *34*, 2994.

(10) Elemental analyses and the melting point agree with those of ref 11: $^1\text{H NMR}$ (C_6D_6) δ 7.3 m (10), 3.3 s (6); IR (Fluorolube) 3060, 3040, 2930, 2900, 2850, 1595, 1575, 1450, 1430, 1345; mp 135 – 137°C dec.

(11) Fischer, E. *Ann.* **1878**, *140*, 67.